



MTP Vacuum Transformer Oil Purification System Mounted On Mobile Trailer

Acore Filtration Co.,Ltd provides engineering, manufacturing, sales of industrial oil filtration systems, we have been striving for studying the user's requirement and provide filtration solutions for every demanding application on global scale.

Acore's filtration systems can help customers improve the quality of oil, extend equipment life, reduce maintenance costs and keep equipment working at peak efficiency. Meanwhile, they are very effective, durable and user-friendly systems.



Introduce:

The principal functions of the insulating fluid are to serve as a dielectric material and an effective coolant. During running of oil-filled electric equipment or transportation, the insulating oil becomes contaminated with moisture, gases and solid particulates, which results in complete deterioration of insulating properties and affect the life of the electric equipment in the long run. So it becomes necessary to maintain optimal insulation properties of oil by controlling over moisture, dissolved gases, particulate contamination.

MTP Mobile Trailer Type Double Stages High Vacuum Transformer Oil Purification System(Oil Purifier Machine) is specially developed for transformer oil degasification, dehydration, filtration processing onsite at outside. It adopts full enclosed structure with function of weather proof. MTP mobile trailer can be carried out on road and off road. Meanwhile, it also works with other electrical insulating oil such as cable, circuit breakers, capacitor etc. The Purification Process of MTP Transformer Oil Purifier is able to maintain complete cleanness and improve dielectric strength of insulating oil. The purification range of MTP vacuum transformer oil purifier is for dielectric insulating oil filled in transformers, circuit breakers, capacitor, cable, mutual inductor etc.

MTP Mobile Trailer Vacuum Transformer Oil Purifier is very effective, durable, and user-friendly high vacuum purification system on the market today. Special engineered design features maximize the water extraction rates of our systems, and top-quality components and workmanship ensure years of maintenance-free operation and performance.

Feature:

- Increasing oil's dielectric strength by effectively removing solid particles, gases and moisture, thus eliminating the need for expensive oil replacement, and thereby extending the life of the electrical equipment.
- Single axle or double axles trailer with functions of weather proof on road or off road.
- Bridge shock absorber, braking system and steel welding of entire trailer guarantee max 80km/h speed.
- Specially designed system in the degassing tank which provides uniform distribution of the processed oil in the low-pressure environment to achieve best treatment results.
- Different pressure gauge of filters, pressure protector, vacuum gauge and digital temperature display



- Digital type electric heating system and safety thermostat, which is designed to allow temperature range of 20-80 °C
- After purification, dielectric strength: $\geq 75\text{kV}$, moisture content: $\leq 3\text{ppm}$, gas content: $\leq 0.05\%$, filtering rating: ≤ 1 micron.
- Online oil purification processing, vacuum drying and vacuum oil-filling for electric equipment.
- Reducing overall operational and maintenance cost of power energy systems.

Technical Specifications

Model	MTP20	MTP30	MTP50	MTP70	MTP100	MTP150	MTP200	MTP250	MTP300	
Capacity(L/hour)	1200	1800	3000	4200	6000	9000	12000	15000	18000	
Vacuum pressure	-0.06~-0.099 Mpa									
Working pressure	≤ 0.4 Mpa									
Temperature range	20 ~ 80°C									
Power supply	208V/220V/380V/400V/415V/440V/460V/480V/575V (+/-10%), 50/60Hz, 3Phase									
Working noise	65 dB									
Continuous running	≥ 100 hours									
No failing running	≥ 5000 hours									
Heating power (kw)	24	30	36	60	72	108	135	155	185	
Total power (kw)	27	35	41	66	80	116	145	165	195	
Inlet/outlet(mm)	25	32	32	40	50	55	60	65	70	
Purifier Weight (kg)	500	650	650	700	900	1110	1300	1500	1750	
Trailer Weight (kg)	350	350	400	500	700	750	850	900	1000	
Purifier Dimension (mm)	L	1500	1600	1600	1700	1850	1950	2050	2150	2250
	W	1400	1400	1450	1550	1750	1800	1850	1900	2000
	H	1500	1500	1550	1650	1800	1800	1850	1900	2000
Trailer Dimension (mm)	L	2800	2800	2800	2800	3200	3500	3600	3800	3900
	W	1500	1500	1500	1600	1800	1850	1900	2000	2100
	H	900	900	900	950	1000	1000	1100	1100	1100

Specifications after treatment:

Item	Specifications
Breakdown voltage	$\geq 75\text{KV}$
Water content	$\leq 3\text{ppm}$
Gas content	$\leq 0.05\%$
Filtering rate	≤ 1 micron (ISO 14/12/10)
Flash point (close cup)	$\geq 135^\circ\text{C}$
Interfacial tension performance	> 40 Dynes / cm @ 25 C
Power factor performance	$< 0.005\%$ @ 25 C
Acid value	≤ 0.03 mgKOH/g

Flow Diagram

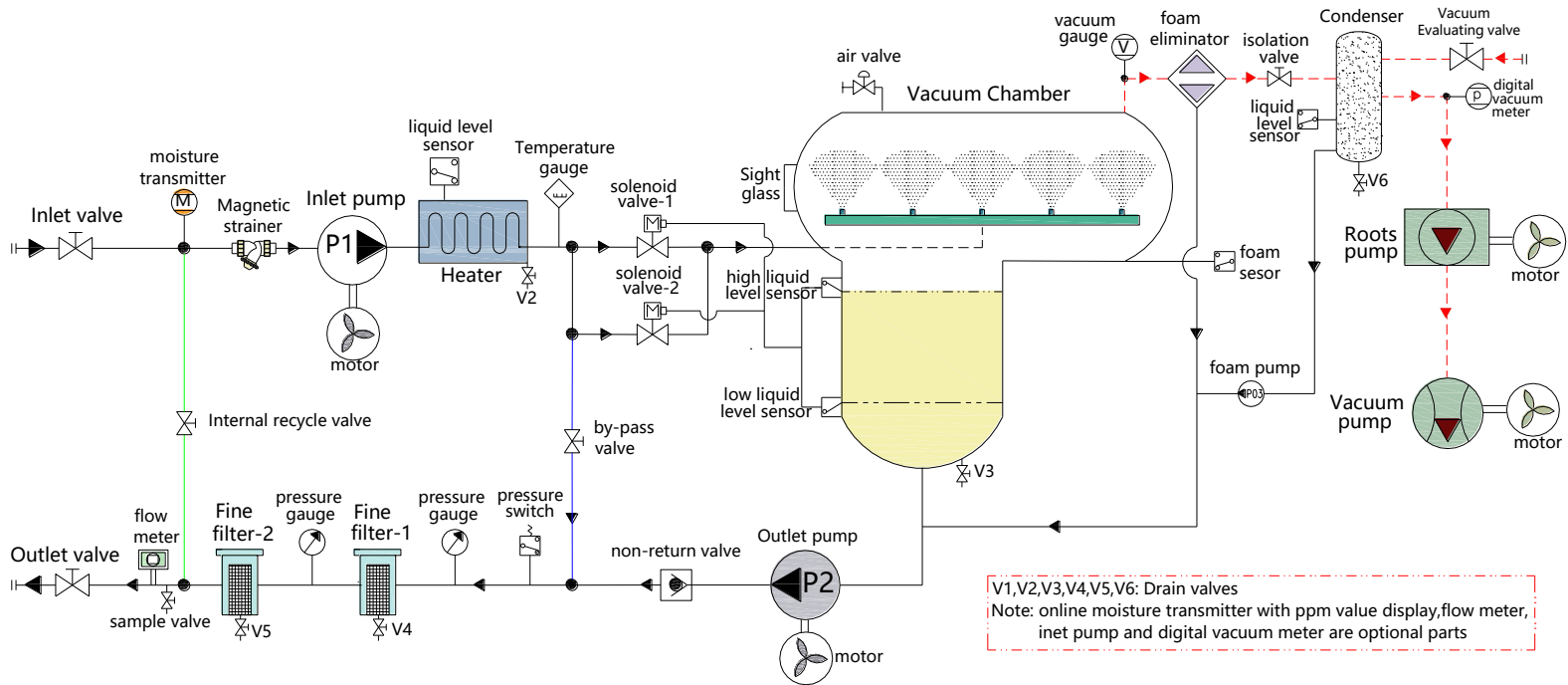

Specification Introduction of Components

1. Electric Controlling System

A sturdily built easily accessible control cabinet housing all the electrical control like contactors, circuit breakers, isolators, relays, selector switches and indicators of running state(for all pumps, heaters, power, etc), interlocking features, alarm indicator, emergency switch, PLC controller, touch screen and all gauges, etc. are provided. All wirings are neatly routed, and all wire terminals shall suitably identified with number ferrules.

The plant can be controlled by a complete automatic PLC system with touch screen, which allows easy and safe operation. It also allows manual operation over switches on the control panel. The controlling system of the plant has interlocked protective system and pressure protective device which will avoid overload, over voltage, pumping without oil, heating without oil, oil leak, electricity leak and prevent any damages to equipment due to operating error or power failure. The control panel also has alarm system for any fault, the alarm lamp will light and fault message will display on screen.

A touch screen is provided with a diagram indicating the state of operation of vacuum pump, roots pump, heaters, inlet pump, outlet pump, liquid level controlling sensors, valves, etc. Meanwhile, Timing counters for each running time and total running time.

2. Vacuum Dehydration & Degasification Chambers

Vacuum chambers are composed of double stages horizontal & vertical vacuum chambers. Under the high vacuum status, vacuum evaporation chambers enlarge evaporation area efficiently, leading to the formation of film-alike oil and stereo-evaporation.

A row of oil mist sprayers with rasching rings are provided in the vacuum chamber and become an evaporator, which spray oil film from down to top and greatly improves the surface area of oil exposed in vacuum system and extends sufficient time to ensure maximum working efficiency in the removal of gas and moisture.

A foam eliminator connected with foam sensor and foam pump to reduce oil foam in vacuum chamber and prevent oil getting into the vacuum pumps and damaging vacuum pump.

An electric vacuum gauge is provided to measures vacuum pressure in vacuum chamber and sight glass are provided for observation of oil flow.

3. Liquid-level Controlling System

The latest magnetic liquid level controlling system with high and low liquid level switch is provided to prevent the oil level in the chamber from getting too high and too low. It connects with inlet/outlet pump, solenoid valves to control balance of inlet and outlet oil quantity, also prevents oil penetrating into vacuum pump and avoid outlet pump running without oil.

An automatic oil foam eliminator connects with foam sensor and foam pump to reduce foam and high oil level.

Automatic solenoid valves and non-return valve are provided to avoid mixing of processed and unprocessed oil, and prevent oil entering degassing chamber in case of power failure.

4. Heating System

The plant equips electric heater with digital temperature gauge, which connects a reliable thermocouple sensor as a safety thermostat mounted in heating vessel, it can check the oil level in heater and avoid heating without oil, at same time, the deterioration of oil caused by overheating is avoided. The temperature can be set by manually and with capable of heating oil from 20°C to 80°C. The designed temperature range can ensure the safety of plant and worker.

The heating components can warm up temperature around and heat radiation container can uniformly warm up the oil, adopting low load of heated surface with 1.5W/cm². The replacement of heating components is easy.

5. Feed Pump & Discharge Pump (Note: Feed Pump is optional)

Feed Pump(inlet pump): Positive inlet pump driven by electric motor to fill oil into plant. An interlocking arrangement is provided between high liquid level switch and inlet pump to avoid excessive rise of oil level in the vacuum chambers, and flow control valve is provided to avoid damage of inlet pump by over-pressure. Meanwhile, an interlocking arrangement is provided between the inlet pump and the heater, so that heater can start only when inlet pump is ON.

Discharge Pump(outlet pump): Discharging oil out from the vacuum chambers held under vacuum. This is fully tested for pressure and vacuum leak rate. An interlocking arrangement between low liquid level switch and discharge pump to prevent running of discharge pump without oil, and flow control valve is provided to avoid damage of outlet pump by over-pressure.

6. Rotary Vane Vacuum Pump & Booster/Roots Pump

A rotary vane vacuum pump combining with vacuum booster(roots) vacuum pump is a sort of vacuum production equipment suitable for pumping air and make the oil purifier working under high vacuum status, this combination can improve the vacuum level more quickly.

Vacuum pump and booster/roots pump installed air cooling systems, which can ensure working of pumps safety and reduces the frequency of oil's replacement and extends the life of vacuum pump. Meanwhile, this combined vacuum pump system can be used for transformers vacuum drying.

7. Filter Elements

The filtering vessels is composed of different precision cartridge filter elements, it features unique design, large filtering area, strong particles-absorbing ability, impurities with different particulate sizes are removed step by step.

Magnetic strainer(Pre-Filter): The magnetic strainer which has strong capacity of retaining all particles above 50 micron. The strainer does not need to be replaced and lifetime is as long as oil purifier.

Fine Filter-1&2: The filter elements is made of specialized polypropylene with constructed stainless steel mesh-pack. It has large impurities holding capacity and can retain 99.5% particles above 1 micron. The particles removal performance can reach ISO 14/12/10.

Pressure gauges and pressure protector is provided to ascertain condition of the filter housing and indicate replacement of filter elements to avoid the overpressure to break the filter elements.

8. Condenser(Oil & Water Trap)

The water and oil foam are collected in the condenser, it has high level liquid sensor which connect a small foam pump to automatically discharge water and oil out from condenser. The condenser is between vacuum pump and vacuum chamber, which can prevent oil getting into vacuum pump system and damaging vacuum pumps.

During transformer evacuating, the condenser also can extract moisture in air, it also can install a dew point transmitter to perform accurate measurement of moisture content of air in transformer and decide when to stop the transformer vacuum drying treatment.

9. Pipe Work

All pipe work, the vacuum chamber and the filter housings are made from high quality carbon steel. The piping joints are flanged type with O'ring sealing.

10. Valves

Different ball valves: inlet/out valves, drain valves of all tanks, electromagnetic /solenoid valves, sample valve, air valve, by-pass valve, etc. are provided.

11. Oil Hoses

Two Nos. transparent steel spring type hoses each 10 meters long with flanged end connection on both sides are provided. Oil Hoses are capable of handling the transformer oil at 100°C (max.) and vacuum.

12. Oil Regeneration Columns (Optional Part)

Oil regeneration device adopts regeneration columns with chemicals for purifying and regenerating the unqualified insulating oil, it is used for removal of acids and soluble surface acting contaminants by adsorption. The transformer oil regeneration device can increase interfacial tension of oil and reduce power factor to required levels. When water and some volatile acids are removed from oil through a prior vacuum process, adsorptive capacity of chemicals for removal of remaining soluble contamination is greatly extended. The regeneration process not only corrects acidity but also removes dirt, dust, carbon, gums, resins, abrasives and oxidation products. It provides complete and dependable protection against costly oil contamination and gives increased operating efficiency to produce better precision product

13. Mobile Trailer & Weather-proof

The oil purifier is mounted on mobile double axles trailer with four (04) tires or single axles trailer with two (02) tires under gear with over run brakes and metallic weather proof canopy. The trailer has articulated front shaft with towing eye and can be towed by truck for moving between different transformer substations. The trailer equips brake system with brake warning light to be synchronized with the pulling truck brake warning light through the electrical connection lead with the truck at max speed of 70km/hour. Meanwhile, the oil purifier with lifting hooks can be unloaded from trailer and mounted on skids.

14. Optional Components or Brand Available

Item	Optional Brands	Optional Components
1.	Siemens or Schneider Electrical Apparatus	Online Moisture Transmitter with digital PPM value display
2.	Siemens PLC Controller and Touch Screen	Digital Flow Meter
3.	Germany Atlas Vacuum Pump	Digital Vacuum Meter to measure vacuum value of transformers
4.	Germany Becker Roots(booster) Pump	Inlet Pump for oil filling without vacuum
5.	Germany Kracht or Italy SEIM Oil Pump	Frequency Converter for Variable Speed Drive
6.	ABB Motor	Portable Dielectric Strength/BDV Tester(AC220V±10%, 50/60hz)